

COLLECTION  
*furniture*

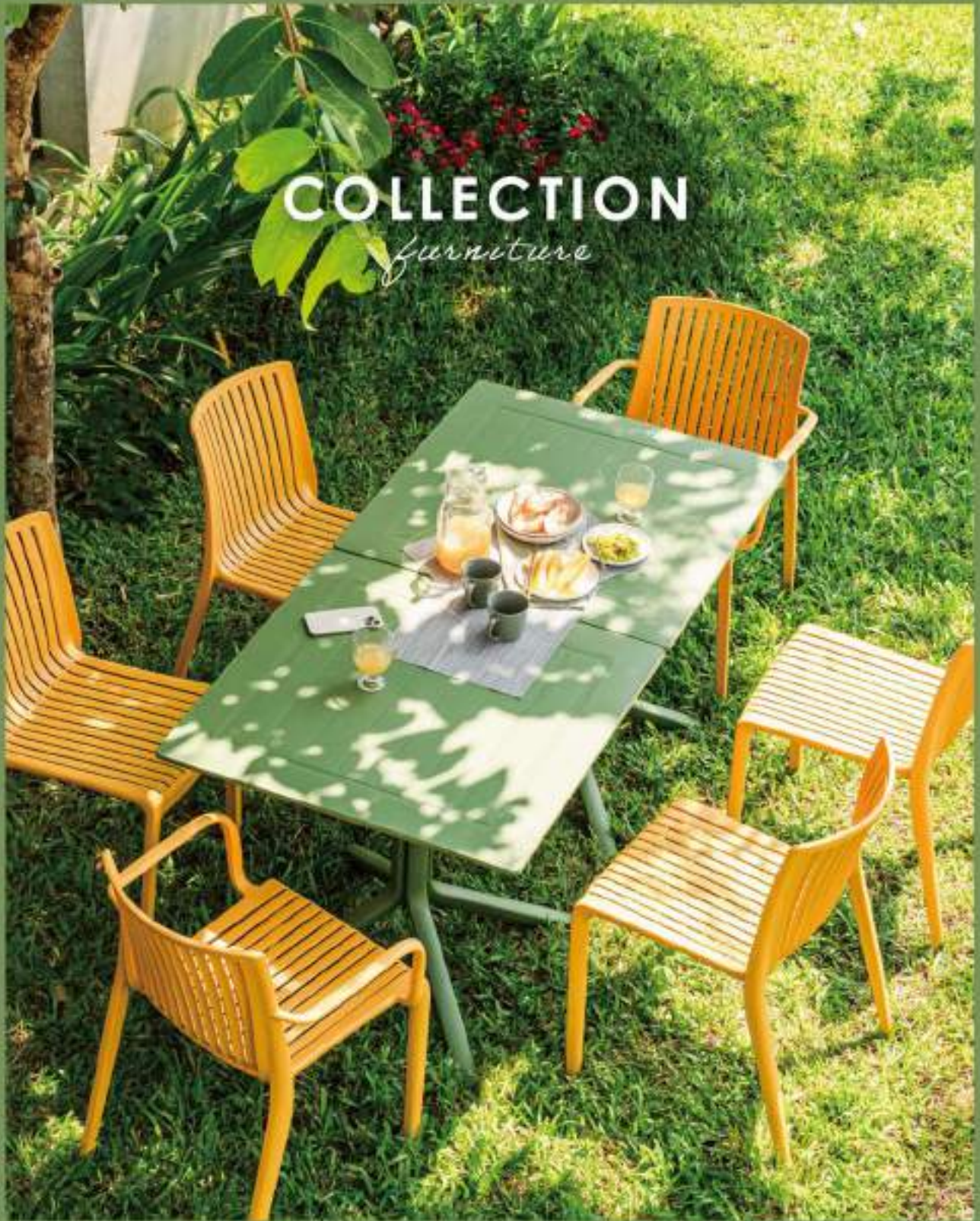

*Lagooni*











# Contents

05	___	Sofa
23	___	Rattan Series
30	___	Milos Series
35	___	Sensilla Series
42	___	Chair
56	___	Armchair
67	___	Counter Stool / Bar Stool
74	___	Rocking Chair / Lounge Chair
78	___	Sun Lounger
83	___	Table
106	___	Case Studies
112	___	Products
121	___	Lagoon Branch Office & Distributor





# New Arrival

7036C / 7036B  
**Rue**

Counter Stool / Bar Stool

A photograph of an outdoor patio area. In the foreground, there are several green plastic stools and two white square tables. The stools have a ribbed backrest and a simple four-legged design. The tables are square and supported by a central black pedestal. The patio is made of light-colored wooden decking. In the background, there is a building with large glass windows and a dark door. The scene is brightly lit, suggesting a sunny day. 

7203BC / 7203BB

# Milos

Counter Stool / Bar Stool





# Venice

7155  
Dining Table



7035 Cooler

# Cancún



# Laurel



## BIFMA (USA)

The Laurel sofa set was inspired by nature's green laurel leaf and its aromatic fragrance, which breathes life into your home. The design adds the poetry of nature to living spaces. With elegant styling, perfect seat height and comfortable cushions, the Laurel sofa set provides a rich and stylish look indoors and adds a glamorous lifestyle outdoors. The versatility of the modular design offers unlimited potential for creating the perfect custom space.





**Laurel**

7215-SS Modular Sofa  
7215-CT Coffee Table

**Seattle**

7101 Coffee Table









**Laurel**  
7215-SS Modular Sofa    7215-CT Coffee Table  
7215-OT Ottoman





**Laurel**

7215-SS Modular Sofa  
7215-OT Ottoman

7215-CT Coffee Table

**Cancún**

7035 Cooler

**Venice**

7155 Dining Table

**Sensilla**

7052 Chair



THE VERSATILITY OF THE MODULAR DESIGN OFFERS UNLIMITED POTENTIAL FOR CREATING THE PERFECT CUSTOM SPACE



SOFA

PRODUCT SPECIFICATION

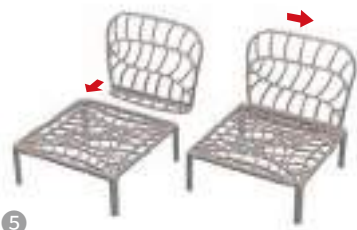

1. Easy to transport by SUV.
2. Perfect for indoor and outdoor use in residential or commercial spaces.
3. Our Polypropylene Quick-Dry Fabrics are engineered to resist mold and mildew. It can be easily cleaned with water.
4. All weather resistant. Easy to keep clean, just wipe with a cloth and water. No chemical cleaners are required.
5. Easy assembly.

# LAUREL

## Club Chair 7215-CC

**MATERIAL**  
Polypropylene + Glass fiber /  
Cushion

**NET WEIGHT**  
14.7kg / 32.3 lb

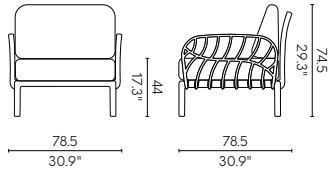

## Additional Seat 7215-S1

**MATERIAL**  
Polypropylene + Glass fiber /  
Cushion

**NET WEIGHT**  
11.2 kg / 24.7 lb

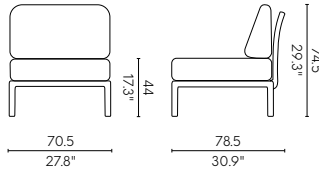

## Loveseat 7215-LC

**MATERIAL**  
Polypropylene + Glass fiber /  
Cushion

**NET WEIGHT**  
25.9 kg / 57 lb

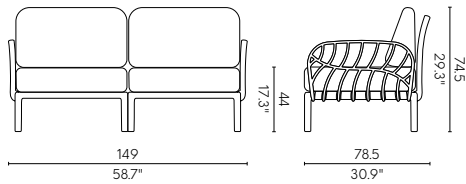

## Loveseat 7215-LL

**MATERIAL**  
Polypropylene + Glass fiber /  
Cushion

**NET WEIGHT**  
22.4kg / 49.4lb

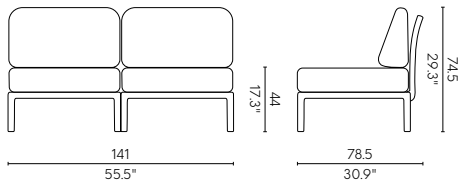

## Sofa 7215-SF

**MATERIAL**  
Polypropylene +  
Glass fiber /Cushion

**NET WEIGHT**  
37.3 kg / 81.6 lb

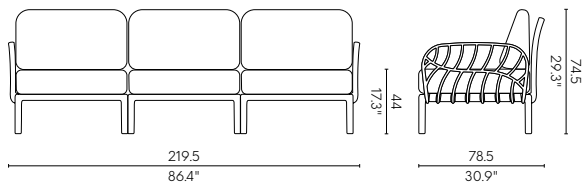

## Corner Chair 7215-CN

**MATERIAL**  
Polypropylene + Glass fiber /  
Cushion

**NET WEIGHT**  
13.6kg / 30lb

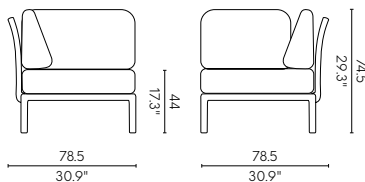



## Modular Sofa 7215-SS

### MATERIAL

Polypropylene + Glass fiber /  
Cushion

### NET WEIGHT

60.8 kg / 134 lb

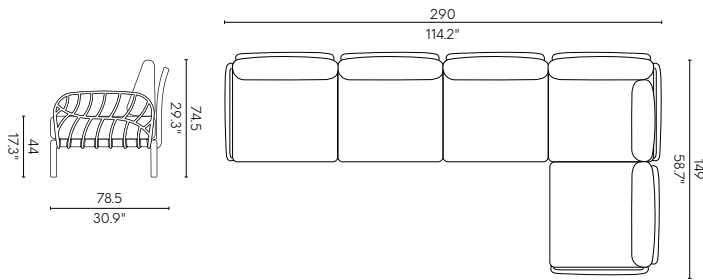

## Chaise Lounge 7215-CL

### MATERIAL

Polypropylene + Glass fiber /  
Cushion

### NET WEIGHT

22.5 kg / 49.6 lb

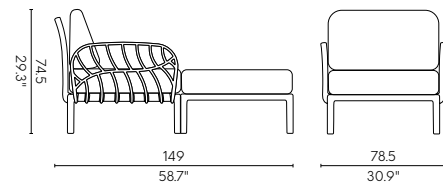

## Ottoman 7215-OT

### MATERIAL

Polypropylene + Glass fiber /  
Cushion

### NET WEIGHT

7.8 kg / 17.2 lb

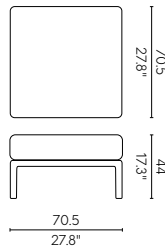

## Coffee Table 7215-CT

### MATERIAL

Polypropylene + Glass fiber

### NET WEIGHT

5.1 kg / 11 lb

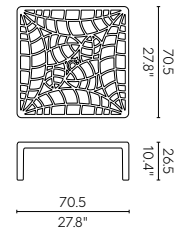

SOFA

## CUSHION



For 7215  
70 x 70 x 16 cm



For 7215  
69 x 19 x 45 cm



For 7215  
54 x 19 x 45 cm

## COLOR



R9



G6



W9

Outdoor 100% polypropylene

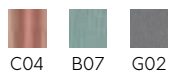

C04 B07 G02

Unit: cm  
inch

The Magnolia series is named for its floral meaning: love of nature, nobility, and literary character. The Magnolia series is noble and elegant, full of literary atmosphere, which can be used indoors and outdoors, and in casual or formal occasions.



# Magnolia

EN581 (EUROPE)





SOFA

**Magnolia**  
7023-SF Sofa

**Uno**  
7095 Side Table

**Russ**  
7022-CT Coffee Table



**Magnolia**  
7023-SF Sofa  
7023-LC Loveseat

7023-OT Ottoman  
7023-ST Side Table

**Uno**  
7095 Side Table





SOFA



# MAGNOLIA

LAGOON FURNITURES

## Club Chair 7023-CC

**MATERIAL**  
Polypropylene / Cushion

**NET WEIGHT**  
15 kg / 33 lb

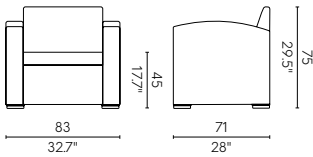

## Additional Seat 7023-S1

**MATERIAL**  
Polypropylene / Cushion

**NET WEIGHT**  
8 kg / 17.6 lb

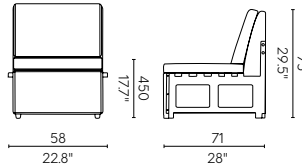

## Loveseat 7023-LC

**MATERIAL**  
Polypropylene / Cushion

**NET WEIGHT**  
23 kg / 50.7 lb

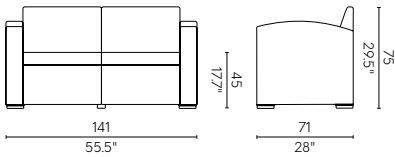

## Ottoman 7023-OT

**MATERIAL**  
Polypropylene / Cushion

**NET WEIGHT**  
5 kg / 11 lb

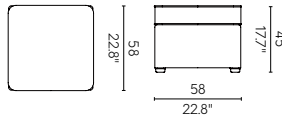

## Sofa 7023-SF

**MATERIAL**  
Polypropylene / Cushion

**NET WEIGHT**  
31 kg / 68.3 lb

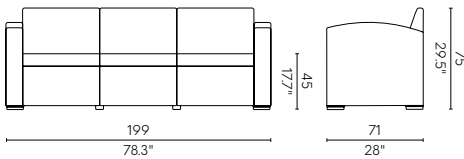

## Side Table 7023-ST

**MATERIAL**  
Polypropylene

**NET WEIGHT**  
4 kg / 8.84 lb

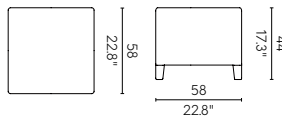

## COLOR



K3

G6

W8

N3

## CUSHION



58 x 58 x 10 cm

58 x 7 x 40 cm

## Outdoor

100% polypropylene

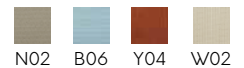

N02

B06

Y04

W02

Unit: cm  
inch

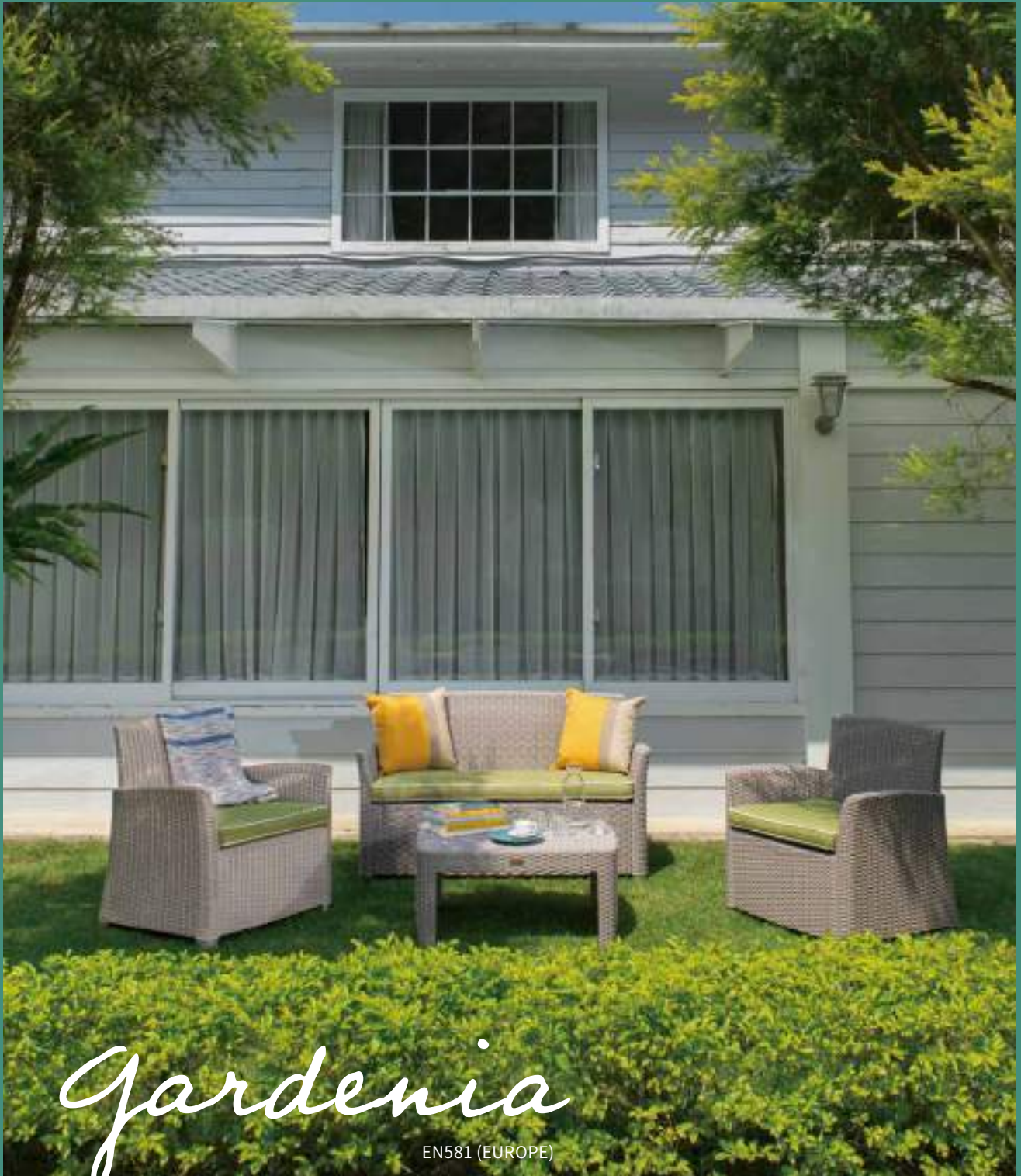

SOFA

# Gardenia

EN581 (EUROPE)

The Gardenia series emphasizes the durable material, just like its floral meaning: eternity and lasting a lifetime. The curves of Gardenia shape were designed according to the lateral-line of a Gardenia flower, similar to a round-rattan and a romantic style. Lagoon rattan furniture consists of high quality and traditional design, and is innovative in its craftsmanship reflecting elegant fashion.





**Duo Russ**  
7032 Relax Table

**Gardenia**  
7026-CC Club Chair



SOFA

**Gardenia**

7026-CC Club Chair

7026-CT Coffee Table



# GARDENIA

## Club Chair 7026-CC

**MATERIAL**  
Polypropylene / Cushion

**NET WEIGHT**  
10 kg / 22 lb

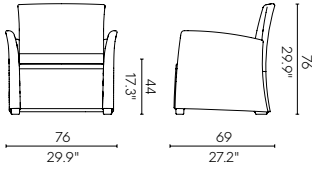

## Loveseat 7026-LC

**MATERIAL**  
Polypropylene / Cushion

**NET WEIGHT**  
17.2kg / 37.8 lb

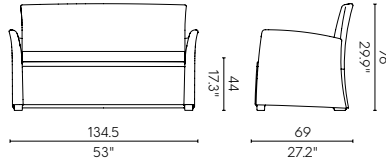

## Coffee Table 7026-CT

**MATERIAL**  
Polypropylene

**NET WEIGHT**  
5 kg / 11 lb

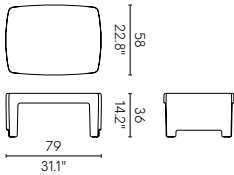

## COLOR



K3

G6

W8

N3



N4

## CUSHION



For 7026-CC  
58 x 52.5 x 6 cm



For 7026-LC  
117 x 52.5 x 6 cm

**Outdoor** 100% polypropylene

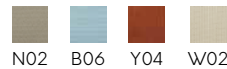

N02

B06

Y04

W02

Unit: cm  
inch

## PRODUCT SPECIFICATION



Modern rattan design, will not unravel like traditional wicker.



Easy to clean and maintain. Just wipe with a cloth and water. No chemical cleansers required.



All materials are environmentally friendly and can be recycled. Our effort to conserve natural resources.



Complete resin design, no metal accessories, will not rust.



All weather resistant resin for both indoor and outdoor use.







**Rue**  
7025 Chair

**Rue**  
7036C Counter Stool



# Rattan Series

With Rue Series, you can bring a stylish and natural look to any indoor or outdoor space. The rattan effect is achieved through a special molding technique that gives the furniture a woven texture similar to natural rattan. These chairs and stools are not only easy to clean and maintain, but can also withstand exposure to harsh weather conditions without losing their color or texture. The Rue Series also coordinates beautifully with a wide range of tables, making it the perfect choice for garden or patio gatherings. Choose from our line of rattan finish, which includes dining chairs, armchairs, bar stools, and counter stools, you'll find the perfect outdoor seating solution for your needs.

RATTAN SERIES



**Rue**  
7036B Bar Stool



**Koppla**  
7027 Armchair







KOPPLA 7027

**MATERIAL**  
Polypropylene

**NET WEIGHT**  
4.7 kg / 10.34 lb

EN581 (EUROPE) JIS(Japan)



LIMITED EDITION



RUE 7025

**MATERIAL**  
Polypropylene

**NET WEIGHT**  
3.9 kg / 8.6 lb

EN581 (EUROPE) JIS(Japan)

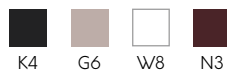

LIMITED EDITION



Unit: cm  
inch





**RUE 7036C**  
Counter Stool

**MATERIAL**  
Polypropylene + Glass fiber /  
Aluminium

**NET WEIGHT**  
4.37 kg / 9.6 lb



**RUE 7036B**  
Bar Stool

**MATERIAL**  
Polypropylene + Glass fiber /  
Aluminium

**NET WEIGHT**  
4.5 kg / 9.9 lb

**BIFMA (USA)**



Unit: cm  
inch





# Milos Series

Introducing the Milos Series, a line of chairs and tall stools that feature a sleek and modern slatted design, perfect for both indoor and outdoor spaces. Made of high-quality polypropylene, these pieces are durable and able to withstand harsh weather conditions without losing their vibrant color. The Milos Series offers a clean and minimalist look that coordinates effortlessly with a variety of table options, making it an ideal choice for any dining set.

LAGOON FURNITURES



**Milos**  
7203B Chair



**Milos**  
7203BC Counter Stool



**Milos**  
7203BB Bar Stool



**Milos**  
7203A Armchair





MILOS 7203A

**MATERIAL**  
Polypropylene + Glass fiber

**NET WEIGHT**  
4.3 kg / 9.5 lb

EN581 (EUROPE)

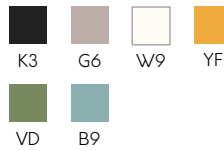



MILOS SERIES

**MILOS 7203B**

**MATERIAL**  
Polypropylene + Glass fiber

**NET WEIGHT**  
4 kg / 8.8 lb

**EN581 (EUROPE)**

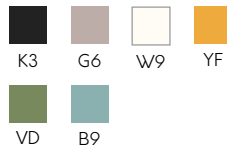
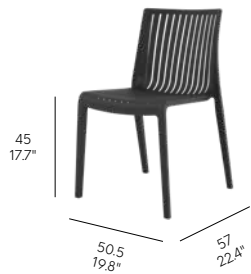

Unit: cm  
inch









**MILOS 7203BC**  
Counter Stool

**MATERIAL**  
Polypropylene + Glass fiber /  
Aluminium

**NET WEIGHT**  
4.7 kg / 10.4 lb

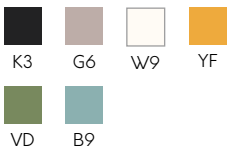

**MILOS 7203BB**  
Bar Stool

**MATERIAL**  
Polypropylene + Glass fiber /  
Aluminium

**NET WEIGHT**  
4.9 kg / 10.8 lb

**BIFMA (USA)**

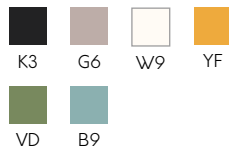
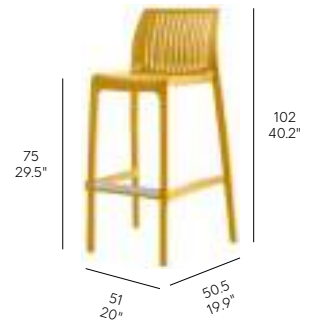

Unit: cm  
inch



# Sensilla Series

When it comes to outdoor seating, durability and comfort are a must-have. Our outdoor seating selection provides both of these features and more. The Sensilla Series offers a simple and contemporary look for any indoor or outdoor space. The chairs and stools in this series have a solid finish achieved through a special molding technique that gives them a clean and modern appearance. The Sensilla Series comes in a variety of colors, making it easy to integrate them into any design scheme. These chairs and stools are versatile enough to be used in various settings, such as outdoor patios, kitchens, bars, and commercial venues like cafes and restaurants.



**Sensilla**  
7052 Chair



**Sensilla**  
7211C Counter Stool



**Sensilla**  
7211B Bar Stool



**Alissa**  
7050 Armchair

SENSILLA SERIES





**SENSILLA 7052**

**MATERIAL**  
Polypropylene + Glass fiber

**NET WEIGHT**  
3.4 kg / 7.5 lb

EN581 (EUROPE)



LIMITED EDITION





ALISSA 7050

**MATERIAL**  
Polypropylene + Glass fiber

**NET WEIGHT**  
4.4 kg / 9.7 lb

**EN581 (EUROPE)**



79.5  
31.3"



G7

G6

W9

YB



V5

BF

LIMITED EDITION



R4

R7

YF

Y7



B7

B9

K5

Unit: cm  
inch





**SENSILLA 7211C**  
Counter Stool

**MATERIAL**  
Polypropylene + Glass fiber

**NET WEIGHT**  
4.7 kg / 10.4 lb

**BIFMA (USA)**



LIMITED EDITION



**SENSILLA 7211B**  
Bar Stool

**MATERIAL**  
Polypropylene + Glass fiber

**NET WEIGHT**  
4.9 kg / 10.8 lb

**BIFMA (USA)**

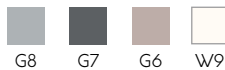
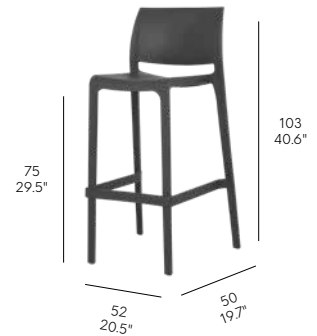

LIMITED EDITION



Unit: cm  
inch



SENSILLA SERIES







CHAIR

### LA VIE 7201

**MATERIAL**  
Polypropylene + Glass Fiber

**NET WEIGHT**  
2.6 kg / 5.7 lb

**BIFMA (USA)**

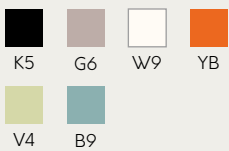

### MILAN 7053

**MATERIAL**  
Polypropylene + Glass fiber

**NET WEIGHT**  
2.8 kg / 6.2 lb

**BIFMA (USA)**



Unit: cm  
inch





## WHALE 7065D

### Leisure

**MATERIAL**  
Polypropylene + Glass fiber

**NET WEIGHT**  
3.8 kg / 8.4 lb

**BIFMA (USA)**

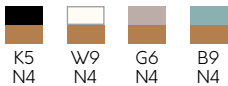

## WHALE 7065F

### Modern

**MATERIAL**  
Polypropylene + Glass fiber / Metal

**NET WEIGHT**  
4.6 kg / 10.1 lb

**BIFMA (USA)**

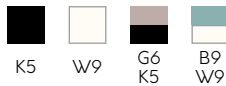

Unit: cm  
inch









CHAIR

## WHALE 7065C

### Classic

#### MATERIAL

Polypropylene + Glass fiber / Metal

#### NET WEIGHT

3.8 kg / 8.4 lb

#### BIFMA (USA)

				
K5	K5 N4	W9 N4	G6 N4	B9 N4

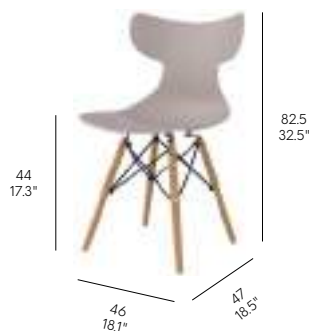

Unit: cm  
inch





X CHAIR 7061

**MATERIAL**  
Polypropylene + Glass Fiber

**NET WEIGHT**  
4.4 kg / 9.7 lb

**BIFMA (USA)**

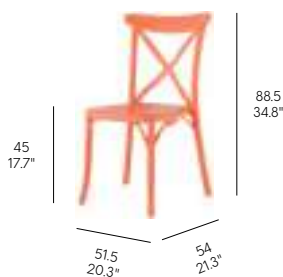

RIO 7062

**MATERIAL**  
Polypropylene + Glass Fiber

**NET WEIGHT**  
4.2 kg / 9.2 lb

**BIFMA (USA)**

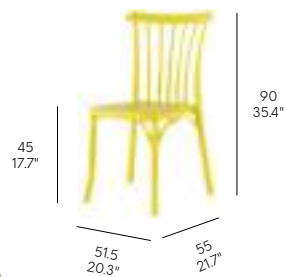



CHAIR

**HERON 7068F**

**Modern**

**MATERIAL**

Polypropylene + Glass Fiber / Metal

**NET WEIGHT**

4.6 kg / 10.1 lb

**BIFMA (USA) JIS(Japan)**



Unit: cm  
inch



## HERON 7068A

### Classic

#### MATERIAL

Polycarbonate + Polypropylene / Metal

#### NET WEIGHT

4.4 kg / 9.7 lb

#### JIS(Japan)

TRANSPARENT



Z1  
R1

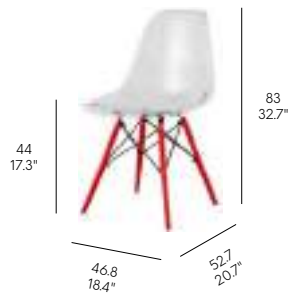

## HERON 7068C

### Classic

#### MATERIAL

Polypropylene + Glass Fiber / Metal

#### NET WEIGHT

3.8 kg / 8.4 lb

#### BIFMA (USA) JIS(Japan)



K5 W9 R1 VB R1  
K5



Unit: cm  
inch



CHAIR





HERON 7068D

Leisure

**MATERIAL**

Polypropylene + Glass Fiber

**NET WEIGHT**

3.8 kg / 8.4 lb

**BIFMA (USA)**





CHAIR

NIDO 7055

**MATERIAL**  
Polypropylene + Glass fiber

**NET WEIGHT**  
5 kg / 11 lb

**BIFMA (USA)**

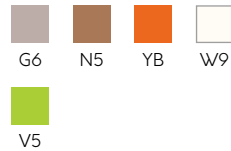
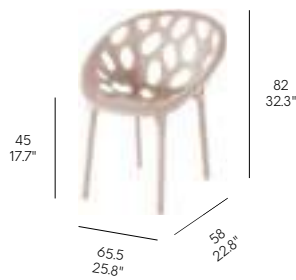

Unit: cm  
inch





PAPILLON 7059

**MATERIAL**  
Polypropylene + Glass fiber

**NET WEIGHT**  
4.5 kg / 9.9 lb

**BIFMA (USA)**



- |   |   |   |   |
|---|---|---|---|
|  |  |  |  |
| Y8  | VB  | BG  | P6  |
| YB  | VC  | BH  | P3  |

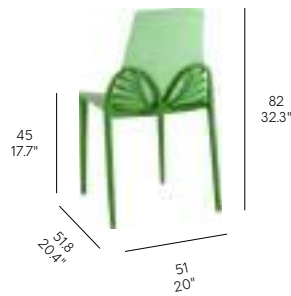

PAVONE 7056

**MATERIAL**  
High impact polystyrene /  
Aluminium alloy

**NET WEIGHT**  
7.2 kg / 15.9 lb



Unit: cm  
inch



CHAIR





ZIGOZAGO 7060A

**MATERIAL**  
Polypropylene + Glass fiber

**FRAMES**  
Painted iron tube

**NET WEIGHT**  
5.5 kg / 12.1 lb

**BIFMA (USA)**



7060A

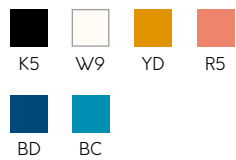

7060B With fabric cover

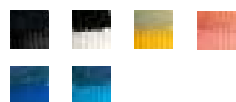



ARMCHAIR

**PENGUIN 7067C**  
Classic

**MATERIAL**  
Polypropylene + Glass fiber / Metal

**NET WEIGHT**  
4.3 kg / 9.5lb

**BIFMA (USA)**

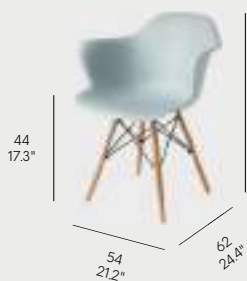

**PENGUIN 7067PC**  
Classic

**MATERIAL**  
Polypropylene + Glass fiber / Metal /  
Faux Leather

**NET WEIGHT**  
4.9kg / 10.8 lb

**BIFMA (USA)**



Unit: cm  
inch





**PENGUIN 7067F**  
Modern

**MATERIAL**  
Polypropylene + Glass fiber /  
Metal

**NET WEIGHT**  
5kg / 11 lb

**BIFMA (USA)**



**PENGUIN 7067PF**  
Modern

**MATERIAL**  
Polypropylene + Glass fiber /  
Metal / Faux Leather

**NET WEIGHT**  
5.6 kg / 12.4 lb

**BIFMA (USA)**



**PENGUIN 7067D**  
Leisure

**MATERIAL**  
Polypropylene + Glass fiber

**NET WEIGHT**  
4.4 kg / 9.7 lb

**BIFMA (USA)**



**PENGUIN 7067PD**  
Leisure

**MATERIAL**  
Polypropylene + Glass fiber /  
Faux Leather

**NET WEIGHT**  
5kg / 11 lb

**BIFMA (USA)**

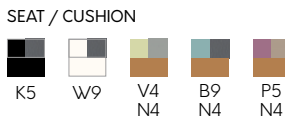

Unit: cm  
inch





### BRAZO 7202

**MATERIAL**  
Polypropylene + Glass fiber

**NET WEIGHT**  
3.6 kg / 7.9 lb

**BIFMA (USA)**

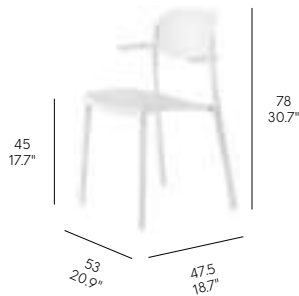
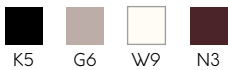



ARMCHAIR

**ELEFANTE 7257**

**MATERIAL**  
Polypropylene

**NET WEIGHT**  
2.1 kg / 4.6 lb

**BIFMA (USA)**

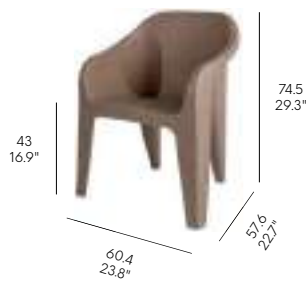

Unit: cm  
inch



### GRACE 7028

**MATERIAL**  
Polypropylene + Glass fiber

**NET WEIGHT**  
4.6 kg / 10.1 lb

**BIFMA (USA)**







ARMCHAIR

IRIS 7029-CC

**MATERIAL**  
Polypropylene + Glass fiber

**NET WEIGHT**  
5.6 kg / 12.3 lb



IRIS 7029-DC

**MATERIAL**  
Polypropylene + Glass fiber

**NET WEIGHT**  
6 kg / 13.2 lb

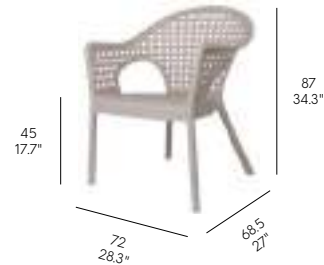

Unit: cm  
inch



CITRUSS 7051

**MATERIAL**  
Polypropylene + Glass fiber

**FRAMES**  
Painted iron tube

**NET WEIGHT**  
3.6 kg / 7.9 lb

EN581 (EUROPE)

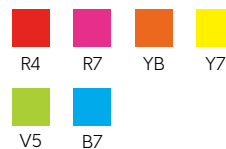



ARMCHAIR

**GARDENIA 7026-DC**  
Dining Chair

**MATERIAL**  
Polypropylene / Cushion

**NET WEIGHT**  
10 kg / 22 lb

**EN581 (EUROPE)**



LIMITED EDITION



**CUSHION** 100% polypropylene

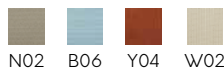

Unit: cm  
inch





**JOYOUS 7057A**  
Stool

**MATERIAL**  
Polypropylene + Glass fiber

**NET WEIGHT**  
2.6 kg / 5.7 lb

**BIFMA (USA) JIS (Japan)**



LIMITED EDITION



Unit: cm  
inch





### JOYOUS 7057C Counter Stool

**MATERIAL**  
Polypropylene + Glass fiber

**NET WEIGHT**  
3.9 kg / 8.6 lb

**JIS (Japan)**



LIMITED EDITION



### JOYOUS 7057B Bar Stool

**MATERIAL**  
Polypropylene + Glass fiber

**NET WEIGHT**  
4.1 kg / 9 lb

**BIFMA (USA)**

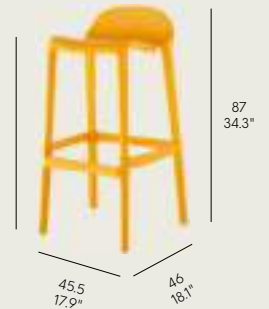

LIMITED EDITION



Unit: cm  
inch





COUNTER STOOL / BAR STOOL







BAR STOOL

**KÖLN 7216**  
Adjustable Bar Stool

**MATERIAL**  
Polypropylene +  
Glass fiber / Metal

**NET WEIGHT**  
12.6 kg / 27.8 lb



59.5-80.5  
23.4"-31.7"



85-106  
33.5"-41.7"

44.5  
17.5"

46.5  
18.3"

**KÖLN 7216P**  
Adjustable Bar Stool

**MATERIAL**  
Polypropylene + Glass fiber /  
Metal / Faux Leather

**NET WEIGHT**  
13.5 kg / 29.8 lb



59.5-80.5  
23.4"-31.7"



85-106  
33.5"-41.7"

44.5  
17.5"

46.5  
18.3"

Unit: cm  
inch





### WHALE 7065G

#### Bar Stool

**MATERIAL**  
Polypropylene + Glass fiber /  
Metal / Wood

**NET WEIGHT**  
5.4 kg / 11.9 lb

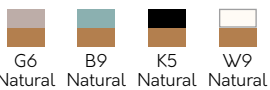



BAR STOOL

**HERON 7068G**  
Bar Stool

**MATERIAL**  
Polypropylene + Glass Fiber / Wood / Metal

**NET WEIGHT**  
5.4 kg / 11.9 lb

**JIS(Japan)**

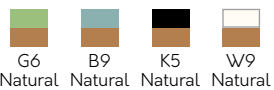

**HERON 7068B**  
Bar Stool

**MATERIAL**  
Polycarbonate / Wood / Metal

**NET WEIGHT**  
6 kg / 13.2 lb

**JIS(Japan)**

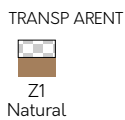

Unit: cm  
inch







### MONSTERA 7066-LX Lounge Chair

**MATERIAL**  
Polypropylene + Glass fiber / Metal /  
Cushion

**NET WEIGHT**  
15.8 kg / 34.8 lb



### MONSTERA 7066-RA Rocking Chair

**MATERIAL**  
Polypropylene + Glass fiber / Cushion

**NET WEIGHT**  
17 kg / 37.5 lb



### MONSTERA 7066-LA Lounge Chair

**MATERIAL**  
Polypropylene + Glass fiber / Cushion

**NET WEIGHT**  
15 kg / 33 lb



### MONSTERA 7066-OX Lounge Chair

**MATERIAL**  
Polypropylene + Glass fiber / Metal /  
Cushion

**NET WEIGHT**  
12.5kg / 27.5 lb

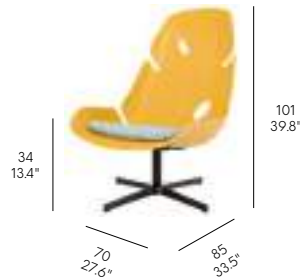

### MONSTERA 7066-PX Lounge Chair

**MATERIAL**  
Polypropylene + Glass fiber / Metal /  
Cushion

**NET WEIGHT**  
14 kg / 30.9 lb



SEAT / CUSHION

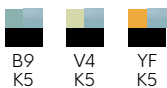

SEAT / CUSHION



Unit: cm  
inch

**MONSTERA 7066-OR**  
Rocking Chair

**MATERIAL**  
Polypropylene +  
Glass fiber / Cushion

**NET WEIGHT**  
12.5 kg / 27.5 lb



SEAT / CUSHION



**MONSTERA 7066-PR**  
Rocking Chair

**MATERIAL**  
Polypropylene +  
Glass fiber / Cushion

**NET WEIGHT**  
13 kg / 28.7 lb

SEAT / CUSHION



Unit: cm  
inch







ROCKING CHAIR





**MONSTERA 7066-OL**  
Lounge Chair

**MATERIAL**  
Polypropylene +  
Glass fiber / Cushion

**NET WEIGHT**  
10.5 kg / 23.1 lb



SEAT / CUSHION

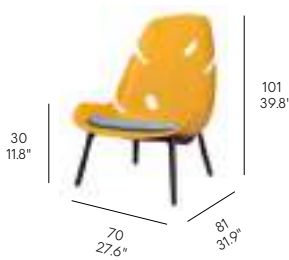

**MONSTERA 7066-PC**  
Lounge Chair

**MATERIAL**  
Polypropylene +  
Glass fiber / Cushion

**NET WEIGHT**  
11 kg / 24.3 lb

SEAT / CUSHION





LOUNGE CHAIR / SUN LOUNGER

**TAHITI 7030**  
Sun Lounger

**MATERIAL**  
Polypropylene

**NET WEIGHT**  
9.4 kg / 20.7 lb

**EN581 (EUROPE)**



Unit: cm  
inch













**HAWAII 7031**  
**Sun Lounger**

**MATERIAL**  
Polypropylene

**NET WEIGHT**  
12 kg / 26.5 lb

**EN581 (EUROPE)**







SUN LOUNGER

ANGEL'S TRUMPET 7058  
Sun Lounger

**MATERIAL**  
Polypropylene

**NET WEIGHT**  
4.2 kg / 9.26 lb

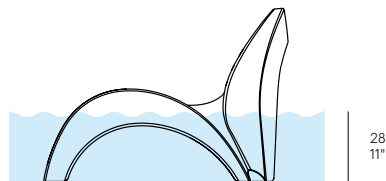

The Angel's Trumpet Chaise Lounge is an ideal companion for complete relaxation on any submerged flat surface within 0-11 inches of water.

Unit: cm  
inch

# Cancún



Our unique Cancún Cooler is purpose-built for the festivities and events. A combined cooler and adjustable-height table, this all-in-one party platform keeps you happy and hydrated all day long. Stash ice and beverages in Cancún's base, and use its top as a table. Durable, easy-cleaning, and available in 6 vibrant colors. You won't find anything like this anywhere else.





TABLE

## CANCÚN 7035

Cooler

**MATERIAL**  
Polypropylene

**NET WEIGHT**  
5.35 kg / 11.79 lb



Ø49  
Ø19.3"

59  
23.2"



Ø49  
Ø19.3"

84

33.1"



K3



G6



W8



N3



YF



V4

Unit: cm  
inch



**VENICE 7155**

**Dining Table**

**MATERIAL**  
Polypropylene + Glass Fiber /  
Metal

**NET WEIGHT**  
12kg / 26.5 lb











**SEATTLE 7101**  
**Dining Table \*2 in 1**

**MATERIAL**  
 Polypropylene

**NET WEIGHT**  
 3.25kg/7.17lb



Ø60  
 Ø23.6"



Ø60  
 Ø23.6"

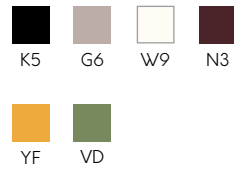





TABLE

**OSLO 7020-DT**  
Dining Table

**MATERIAL**  
Polypropylene / Painted  
galvanized iron tube

**NET WEIGHT**  
14.1 kg / 31.1 lb

**EN581 (EUROPE)**

**OSLO 7020-D2**  
Dining Table

**MATERIAL**  
Polypropylene / Aluminum tube

**NET WEIGHT**  
9 kg / 19.8 lb

**EN581 (EUROPE)**



Unit: cm  
inch







TABLE

**OSLO FAMILY 7021-DT**  
Dining Table

**MATERIAL**  
Polypropylene / Painted galvanized iron tube

**NET WEIGHT**  
20.9 kg / 46 lb

EN581 (EUROPE)

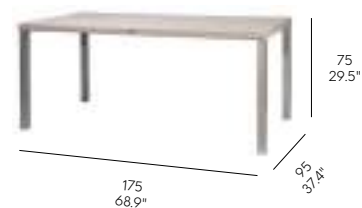

**OSLO FAMILY 7021-D2**  
Dining Table

**MATERIAL**  
Polypropylene / Aluminum tube

**NET WEIGHT**  
14.5 kg / 32 lb

EN581 (EUROPE)

Unit: cm  
inch

### RUSS 7022-CT Coffee Table

**MATERIAL**  
Polypropylene / Painted  
galvanized iron tube

**NET WEIGHT**  
6.8 kg / 15 lb

EN581 (EUROPE)

### RUSS 7022-C2 Coffee Table

**MATERIAL**  
Polypropylene / Aluminum tube

**NET WEIGHT**  
4.15 kg / 9.2 lb

EN581 (EUROPE)



### RUSS 7022-DT Dining Table

**MATERIAL**  
Polypropylene / Painted  
galvanized iron tube

**NET WEIGHT**  
8.8 kg / 19.4 lb

EN581 (EUROPE)

### RUSS 7022-D2 Dining Table

**MATERIAL**  
Polypropylene / Aluminum tube

**NET WEIGHT**  
4.85 kg / 10.7 lb

EN581 (EUROPE)



### RUSS 7022-L2 Island Table

**MATERIAL**  
Polypropylene / Aluminum tube

**NET WEIGHT**  
5.95KG/13.11 lb

EN581 (EUROPE)



### RUSS 7022-BT Bar Table

**MATERIAL**  
Polypropylene / Painted  
galvanized iron tube

**NET WEIGHT**  
12.5 kg / 27.6 lb

EN581 (EUROPE)

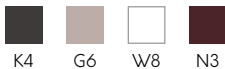

### RUSS 7022-B2 Bar Table

**MATERIAL**  
Polypropylene / Aluminum tube

**NET WEIGHT**  
6.15 kg / 13.6 lb

EN581 (EUROPE)



BT

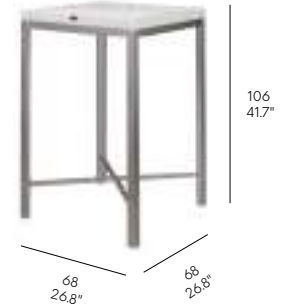

B2

Unit: cm  
inch











## DUO RUSS 7032-CT Coffee Table

**MATERIAL**  
Polypropylene / Painted  
galvanized iron tube

**NET WEIGHT**  
10.5 kg / 23.15 lb

EN581 (EUROPE)

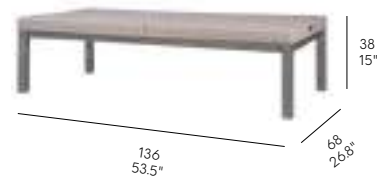

## DUO RUSS 7032-RT Relax Table

**MATERIAL**  
Polypropylene / Painted  
galvanized iron tube

**NET WEIGHT**  
10.5 kg / 23.15 lb

EN581 (EUROPE)

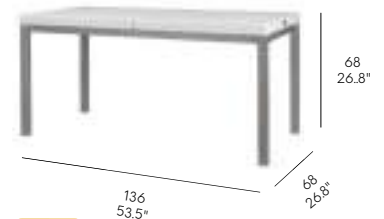

## DUO RUSS 7032-DT Dining Table

**MATERIAL**  
Polypropylene / Painted  
galvanized iron tube

**NET WEIGHT**  
12.5 kg / 27.56 lb

EN581 (EUROPE)



Unit: cm  
inch





**HERON 7168B-DT**  
Dining Table

**MATERIAL**  
Polypropylene / Metal

**NET WEIGHT**  
8.2 kg / 18.1 lb

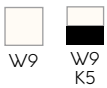

TABLE

**HERON 7168B-LT**  
Island Table

**MATERIAL**  
Polypropylene / Metal

**NET WEIGHT**  
9.6 kg / 21.2 lb

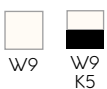

**HERON 7168B-BT**  
Bar Table

**MATERIAL**  
Polypropylene / Metal

**NET WEIGHT**  
9.8 kg / 21.6 lb



Unit: cm  
inch



OULU 7167-DT  
Dining Table

**MATERIAL**  
Polypropylene / Metal

**NET WEIGHT**  
7.4 kg / 16.3 lb

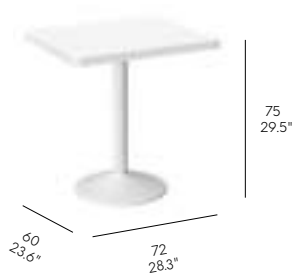





TABLE

**OULU 7167-LT**  
Island Table

**MATERIAL**  
Polypropylene / Metal

**NET WEIGHT**  
8.6 kg / 19 lb



**OULU 7167-BT**  
Bar Table

**MATERIAL**  
Polypropylene / Metal

**NET WEIGHT**  
8.9 kg / 19.6 lb



108  
42.5"

Unit: cm  
inch



**HERON 7169B-DT**  
Dining Table

**MATERIAL**  
Polypropylene / Metal

**NET WEIGHT**  
18.5 kg / 40.8 lb







TABLE

**HERON 7169**  
Dining Table

**MATERIAL**  
Polypropylene / Metal

**NET WEIGHT**  
11.8kg / 26 lb

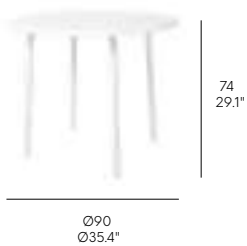

**HERON 7168**  
Dining Table

**MATERIAL**  
Polypropylene / Metal

**NET WEIGHT**  
7.4kg / 16.3 lb

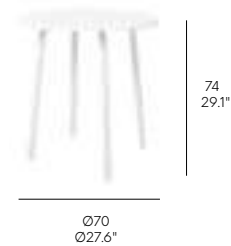

Unit: cm  
inch



**CHLOE GARDEN 7097**  
Dining Table

**MATERIAL**  
Polypropylene + Glass fiber

**NET WEIGHT**  
11 kg / 24.3lb



74  
29.1"

Ø90  
Ø35.4"





TABLE

**ELEPHANT TABLE 7157**  
**Dining Table**

**MATERIAL**  
 Polypropylene

**NET WEIGHT**  
 5 kg / 11 lb



Unit: cm  
 inch





**MALLORCA 7033A**  
Side Table / Stool

**MATERIAL**  
Polypropylene + Glass fiber

**NET WEIGHT**  
1.75kg / 3.9 lb



 Rattan Top



**MALLORCA 7033B**  
Side Table / Stool

**MATERIAL**  
Polypropylene + Glass fiber

**NET WEIGHT**  
1.88 kg / 4.1 lb

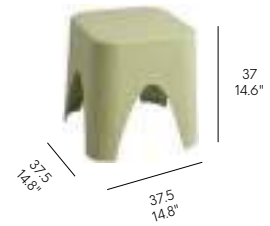

 Flat Top





TABLE

**SPROUT 7090**  
**Dining Table** \*2in1

**MATERIAL**  
 Polypropylene

**NET WEIGHT**  
 5 kg / 11 lb



Ø57  
 Ø22.4"



Ø57  
 Ø22.4"

74  
 29.1"

58  
 22.8"



K3



W9



YB  
 W9

Unit: cm  
 inch



**UNO 7095**  
**Side Table**

**MATERIAL**  
Polypropylene + Glass fiber

**NET WEIGHT**  
2.7kg / 5.9 lb





# Case Studies

## CASAS COYOLITO



Location : 300mts Entrada Apostadero Naval,  
Coyolito, Honduras  
Web : <https://www.casascoyolito.com/>

**Tahiti**  
7030 Sun Lounger  
**Koppla**  
7027 Armchair

**Sensilla**  
7211B Bar Stool  
**Oslo**  
7020-DT Dining Table

**Rue**  
7025 Chair  
**Oslo Family**  
7021-DT Dining Table

**Angel's Trumpet**  
7058 Lounge Chair

## CHICKEN RANCH PALM SPRINGS



Location: Mariscal Foch E7-81 & Diego de Almagro Quito, Ecuador  
Web : <https://eatchickenranch.com/>

**Alissa**  
7050 Armchair

## PALM MOUNTAIN RESORT & SPA



Location: 155 SOUTH BELARDO, PALM SPRINGS, CA 92262  
Web : <https://www.palmmountainresort.com/>



**Monstera**  
7066OL Lounge Chair

## VISTA RESTAURANT



Location : 5020 NE 2nd Ave. Miami, Florida 33137  
Web : <https://vistamiamirestaurant.com/>



**Rue**  
7025 Chair



## QIN ORIENTAL FOOD



Location: Los Gavilanes, C.P. 45603, Jalisco Local RN04  
Web : <https://www.qin.mx/>



**Sensilla**  
7052 Chair

## VIVE CAFETO



Location: Av. Punto Sur 235, Los Gavilanes, 45645 Los Gavilanes  
Web : <https://www.vivecafeto.mx/nochescafeto>



**Rue**  
7025 Chair

## DR. LIMÓN CEVICHE BAR



Location: 10548 SW 8th St, Miami, FL 33174  
Web : <https://www.doctorlimon.com/dr-limon-Fiu/>



**Sensilla**  
7052 Chair

## KOFFI CENTRAL PALM SPRINGS



Location: 650 E Tahquitz Canyon Way Palm Springs, CA 92262  
Web : <https://kofficoffee.com/?v=7516fd43adaa>



**Alissa**  
7050 Armchair



## BALAN HILL GLAMPING



Location: No. 6, 2-6, Wenzheng Lane, 8 adjacent to Zhongming Village,  
Yuchi Township, Nantou County, Taiwan  
Web : <http://www.balanhill.com/zh-tw/>

**Sensilla**  
7211B Bar Stool

**La Vie**  
7201 Chair

**Heron**  
7168B-BT Bar Table  
7168B-DT Dining Table

## GIVE ME SMOOTHIE



Location : No. 386, Dongqiao 7th Rd., Yongkang Dist., Tainan City 710038 , Taiwan  
Web : <https://www.facebook.com/Givemesmoothie/>

**HERON**  
7168B-DT Dining Table

**PENGUIN**  
7067F Armchair





# Products



LAUREL  
7215-CC  
P.11



LAUREL  
7215-LC  
P.11



LAUREL  
7215-SF  
P.11



LAUREL  
7215-S1  
P.11



LAUREL  
7215-LL  
P.11



LAUREL  
7215-CN  
P.11



LAUREL  
7215-SS  
P.12



LAUREL  
7215-CL  
P.12



LAUREL  
7215-OT  
P.12



LAUREL  
7215-CT  
P.12



**MAGNOLIA**  
7023-CC  
P.17



**MAGNOLIA**  
7023-LC  
P.17



**MAGNOLIA**  
7023-SF  
P.17



**MAGNOLIA**  
7023-S1  
P.17



**MAGNOLIA**  
7023-OT  
P.17



**MAGNOLIA**  
7023-ST  
P.17



**GARDENIA**  
7026-CC  
P.21



**GARDENIA**  
7026-LC  
P.21



**GARDENIA**  
7026-CT  
P.21





RUE  
7205  
P.26



KOPPLA  
7207  
P.25



RUE COUNTER  
72036C  
P.27



RUE BAR  
72036B  
P.28



MILOS B  
7203B  
P.32



MILOS A  
7203A  
P.31



MILOS COUNTER  
7203BC  
P.34



MILOS BAR  
7203BB  
P.33



SENSILLA  
7052  
P.37



ALISSA  
7050  
P.38



SENSILLA COUNTER  
7211C  
P.39



SENSILLA BAR  
7211B  
P.40



MILAN  
7053  
P.42



NIDO  
7055  
P.52



PAVONE  
7056  
P.54



PAPILLON  
7059  
P.53



ZIGOZAGO  
7060A  
P.55



X CHAIR  
7061  
P.47



RIO  
7062  
P.47



WHALE  
7065C  
P.46



WHALE  
7065D  
P.43



WHALE  
7065F  
P.44



HERON  
7068C  
P.49



HERON  
7068A  
P.49



HERON  
7068D  
P.51



HERON  
7068F  
P.48



LA VIE  
7201  
P.41



GARDENIA  
7026-DC  
P.64



GRACE  
7028  
P.61



IRIS  
7029-CC  
P.62



IRIS  
7029-DC  
P.62



CITRUSS  
7051  
P.63



PENGUIN  
7067C  
P.56



PENGUIN  
7067PC  
P.56



PENGUIN  
7067D  
P.58



PENGUIN  
7067PD  
P.58



PENGUIN  
7067F  
P.58



PENGUIN  
7067PF  
P.58



BRAZO  
7202  
P.59



ELEFANTE  
7257  
P.60



JOYOUS  
7057A  
P.65



JOYOUS COUNTER  
7056C  
P.67



JOYOUS BAR  
7057B  
P.68



WHALE  
7065G  
P.71



HERON  
7068B  
P.72



HERON  
7068G  
P.72



KÖLN  
7216  
P.69



KÖLN  
7216P  
P.70





MONSTERA  
7066-RA  
P.74



MONSTERA  
7066-LA  
P.74



MONSTERA  
7066-LX  
P.74



MONSTERA  
7066-OX  
P.74



MONSTERA  
7066-PX  
P.74



MONSTERA  
7066-OR  
P.75



MONSTERA  
7066-PR  
P.75



MONSTERA  
7066-OL  
P.77



MONSTERA  
7066-PC  
P.77



TAHITI  
7030  
P.78



HAWAII  
7031  
P.81



ANGEL'S TRUMPET  
7058  
P.82



**VENICE**  
7155  
P.85



**OULU**  
7167-DT  
P.97



**OULU**  
7167-LT  
P.98



**OULU**  
7167-BT  
P.98



**OSLO**  
7020-DT / D2  
P.88



**RUSS**  
7022-CT / C2  
P.91



**RUSS**  
7022-DT / D2  
P.91



**RUSS**  
7022-L2  
P.91



**RUSS**  
7022-BT  
P.91



**RUSS**  
7022-B2  
P.91



**OSLO FAMILY**  
7021-DT / D2  
P.90



**DUO RUSS**  
7032-DT  
P.94



**DUO RUSS**  
7032-RT  
P.94



**DUO RUSS**  
7032-CT  
P.94



HERON  
7169B-DT  
P.99



HERON  
7168B-DT  
P.96



HERON  
7168B-LT  
P.96



HERON  
7168B-BT  
P.96



HERON  
7168  
P.100



HERON  
7169  
P.100



CHLOE GARDEN  
7097  
P.101



ELEFANTE TABLE  
7157  
P.102



CANCÚN  
7035  
P.84



SPROUT •2 in 1  
7090  
P.104



SEATTLE •2 in 1  
7101  
P.87



UNO  
7095  
P.105



MALLORCA  
7033A  
P.103



MALLORCA  
7033B  
P.103





# Lagoon Branch office & Distributor

## USA

---

### SAN DIEGO, CA

8070 ST. ANDREWS AVENUE, SUITE 106,  
SAN DIEGO, CA 92154  
TEL: (619) 267-0345  
fox\_hu@lagoonconceptstore.com

### MIAMI, FL

8947 NW 23RD STREET, DORAL, FL 33172, USA  
TEL: (786) 420-2934  
fox\_hu@lagoonconceptstore.com

### SAN DIEGO SHOWROOM

4689 CONVOY ST., SAN DIEGO, CA 92111  
TEL: (619) 267-0345  
fox\_hu@lagoonconceptstore.com

### HIGH POINT MARKET SHOWROOM

SUITES AT MARKET SQUARE M-1043

### ATLANTA MARKET SHOWROOM

ATLANTA MARKET SHOWROOM BUILDING 2, 9A-11

## MEXICO

---

### TIJUANA, BAJA CALIFORNIA

CALLE COCHIMIES NO.18480, INT.821-D,  
COL. GUAYCURA, TIJUANA, BAJA CALIFORNIA, C.P.  
22216  
TEL: (664) 625-1552  
sales@merrytech.com.mx

### SUCURSAL GUADALAJARA, JALISCO

CIRCUITO DE LA PRODUCTIVIDAD # 215,  
PARQUE IND. GUADALAJARA, COL. LAS PINTAS,  
MUNICIPIO DE EL SALTO, JALISCO C.P. 45690  
TEL: (33) 3345-0660 / (33) 3345-0661 /  
(33) 3345-0586

ohuerta@merrytech.com.mx

### SUCURSAL MONTERREY, NUEVO LEÓN

BLVD. CARLOS SALINAS DE GORTARI #1500,  
BODEGA 6 CRUCE CON AV. CONCORDIA, CENTRO  
DE APODACA, C.P. 66600, APODACA, NUEVO LEÓN  
TEL: (81) 8351-8492 / (81) 1334-1044

tlin@merrytech.com.mx

### SUCURSAL CDMX

AV. PONIENTE 140 #840, BDG. 15-C, COL.  
INDUSTRIAL VALLEJO, ALCALDÍA AZCAPOTZALCO,  
CIUDAD DE MÉXICO, C.P. 02300  
TEL: (55) 5368-0907 / (55) 5368-0905  
alemus@merrytech.com.mx

### TIENDA PUERTO VALLARTA, JALISCO

CARRETERA TEPIC – PTO. VALLARTA #5393, LOCAL 1,  
COL. LAS JUNTAS, PUERTO VALLARTA, JALISCO, C.P.  
48291

TEL: (322) 114-5371

pvr@muebleslagoon.mx

### TIENDA LEÓN, GUANAJUATO

AV. ROMA 805, ANDRADE, LEÓN, GUANAJUATO, C.P.  
37020

TEL: (477) 274-2047

lagoonleon.ventas@gmail.com

### TIENDA COLIMA, COLIMA

AV. CONSTITUCIÓN 1599, JARDINES VISTA HERMOSA  
IV, 28017 COLIMA, COLIMA.

TEL: (312) 314-9911

fernando@gaudi.com.mx

## MALAYSIA & SINGAPORE

---

NO.5, JALAN SILC 1/8, KAWASAN PERINDUSTRIAN  
SILC,79200 ISKANDAR PUTERI, JOHOR, MALAYSIA  
TEL: +607 595 0069 / +6016 725 2894

E-MAIL : sales@sunnyward.com

## TAIWAN

---

### Lagoon International Corporation

4F., NO.222, SEC. 3, DATONG RD., XIZHI DIST.,  
NEW TAIPEI CITY 221, TAIWAN(R.O.C.)

TEL: 886-2- 86471234 886-2- 86471688

FAX: 886-2- 86471768

sales.rep@mail.lagoon.com.tw



Lagoon International Corporation  
[www.lagoonfurniture.com](http://www.lagoonfurniture.com)

All Lagoon chairs are certified by one or more  
of the following: BIFMA, EN581, JIS.

**Lagoon International Corporation**

4F, No.222, Sec.3, Datong Rd., Xizhi Dist., New Taipei City 221, Taiwan(R.O.C.)  
TEL: 886-2- 86471234 886-2- 86471688 FAX: 886-2- 86471768  
E-mail : [sales.rep@lagoon.com.tw](mailto:sales.rep@lagoon.com.tw)